

## INSTALLATION OF HMS™ HOOK MOUNT SYSTEM ON FRONT WHEELS

### TOOLS NEEDED

#3 or #4 Phillips Head Screwdriver

### VERY IMPORTANT

Read And Understand These Steps Before Installation!

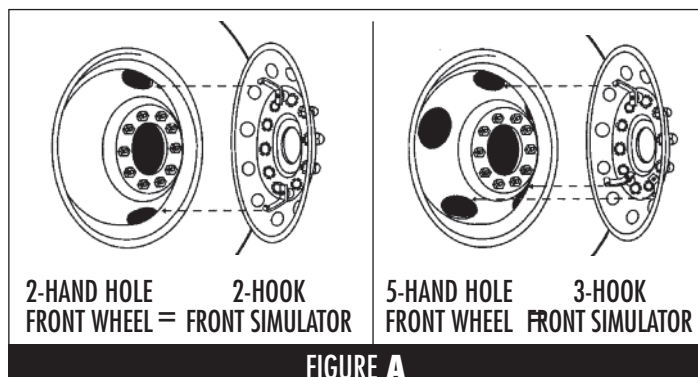

### Step 1. Check Wheels Before Installing Simulators

Before you start check your front wheels to determine whether you have an "EVEN" or "ODD" number of hand holes in the wheel. The number of hand holes in the wheel determines the correct HMS Hook Mount System you will need for proper installation of your wheel covers. (See Fig. A).

**Note:** Certain 4-hand hole wheels require a 4-hook system (not shown).

### Step 2. Installing Front Wheel Simulator

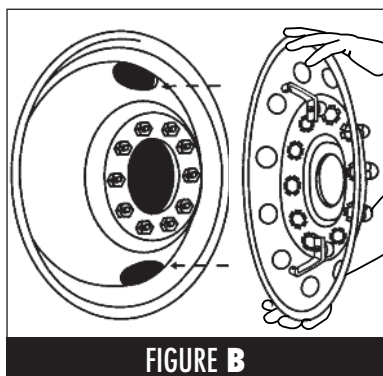

Line up the mounting hooks on the back of the wheel simulator with the hand holes of the wheel. (See Fig. B).

**Note:** On 2-hand hole wheels and Ford F450-550s with 5-hand hole wheels, one of the hooks must insert into the hand hole that has the air valve.

Gently push the wheel simulator against the wheel until one of the hooks engage into one of the wheel hand holes. (See Fig. C). Then continue one at a time engaging each hook into the other hand holes depending on 2, 3, or 4 hook system.

**Note:** You may have to loosen the Phillips head screws a little before all the hooks will engage.

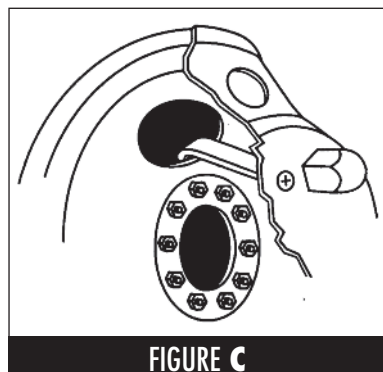

### Step 3. Proper Engagement And Tightening

Make sure all the hooks have engaged into the proper hand holes of the wheel. Next begin alternating tightening each Phillips head screw a few turns.

**(Very Important:** Look into the holes of the simulator where the hooks are and see that the hooks are engaged onto the center portion of the wheel hand holes.) (See Fig. C-1). Next carefully feel with your fingers through the holes in the simulator, to make sure the mounting hooks are fully engaged onto the center of the hand holes (See Fig. D). As you continue alternating tightening each hook, keep your fingers in the holes of the simulator where you're tightening to make sure the hook stays engaged and in the center of the wheel hand holes.

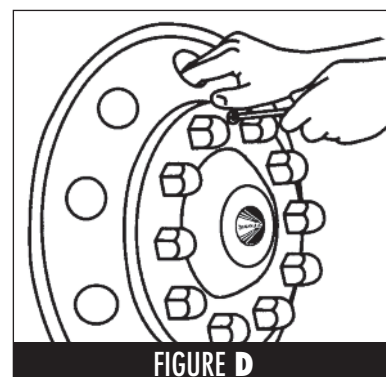
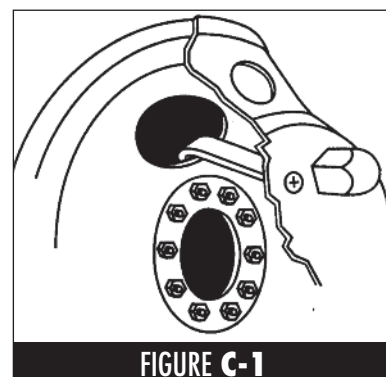

### Step 4. Verify Wheel Simulator Is Centered On Wheel

At this point stop alternating tightening the Phillips head screws, and check to see that the simulator is being tightened evenly all the way around the simulator and rim. Slide your hands around the edge of the simulator and rim, making sure the simulator is evenly spaced all the way around the rim. (See Fig. E). If it's not even, you may have to loosen the screws and readjust the simulator so that it is centered around the rim, then repeat the tightening procedure in Step 3.

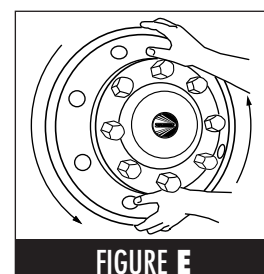

### Step 5. Final Tightening Of Wheel Simulator / Removal

After final checking that the hooks are engaged into the center of the hand holes of the wheel and the simulator is evenly spaced and true all the way around the rim, then continue to alternate tightening the Phillips head screws until the simulator is securely tightened to the wheel. **To Remove The Simulator:** Loosen the Phillips head screws until the hook mounts disengage from the hand holes.

**Very Important:** After initial installation, the mounting system will seat itself into the wheel. After the first 100 miles check that the simulators are tight and secure to the wheels. If necessary retighten the mounting screws. We recommend that the wheel simulators are checked and inspected periodically to make sure that they are tight and secure to the wheels.

**INSTALLATION OF HMST™ HOOK MOUNT SYSTEM ON REAR WHEELS**

**TOOLS NEEDED**

#3 or #4 Phillips Head Screwdriver

**VERY IMPORTANT**

**Read And Understand These Steps Before Installation!**

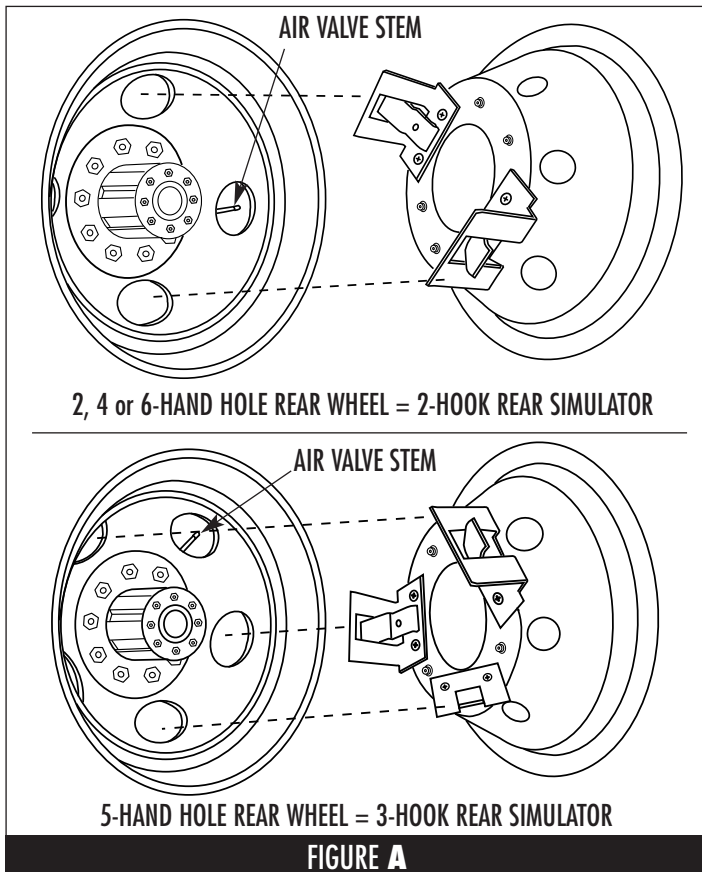

**Step 1. Check Wheels Before Installing Simulators**

Check your rear wheels to determine whether you have an “EVEN” or “ODD” number of hand holes in the wheel. The number of hand holes in the wheel determines the correct Hook Mount System you will need to properly install your Rear wheel simulators (See Figure A).

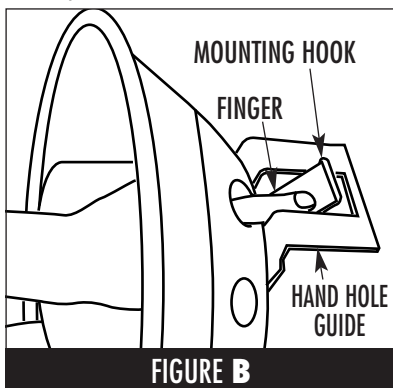

Place a finger into two of the simulator holes where the mounting hooks are and push the mounting hooks back towards the wheel. (See Fig. B). Next align the hand hole guides with the hand holes in the wheel. **NOTE:** Make sure the hand hole guides go into the hand holes opposite the air valve. (See

Fig. A) Gently push the simulator in until it is firmly against the rim.

**Note:** If the hooks do not go into the hand holes, pull the simulator off and loosen the phillips head screws on the front side of the simulator. Then again with your fingers through the two holes push the mounting hooks back and reinstall the simulator back into the wheel making sure the mounting hooks go into the hand holes of the wheel.

**Step 3. Tightening Rear Wheel Simulators**

Next with your Phillips head screwdriver turn each screw in until snug (not tight). Next, check to make sure the simulator is firmly against the rim and evenly spaced around the rim, side to side, and top to bottom. (See Fig. D). Also look into the two holes of the simulator where the mounting hooks are and make sure the mounting hooks are properly engaged into the hand holes. If possible, look between the duals to see that the hand hole guides and mounting hooks are engaged properly. (See Fig. C) If all is correct, alternate tightening the Phillips head screw until the simulator is tightened securely to the rim. (See Fig. E) After vehicle has been driven, periodically check to make sure the Phillips head screws are tight.

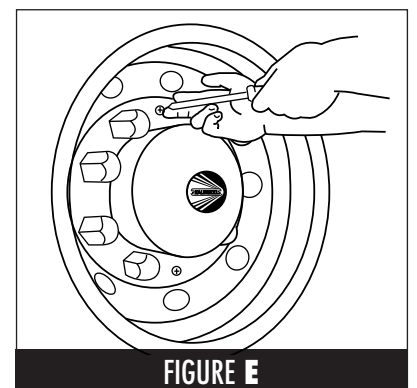
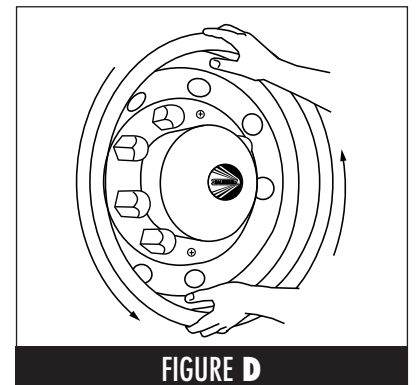
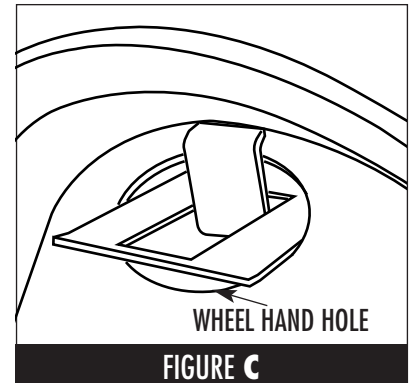

**Removal**

To remove simulators, loosen screws until they are back far enough to disengage themselves from the hand holes.

**Very Important:** After initial installation, the mounting system will seat itself into the wheel. After the first 100 miles check that the simulators are tight and secure to the wheels. If necessary retighten the mounting screws. We recommend that the wheel simulators are checked and inspected periodically to make sure that they are tight and secure to the wheels.